

# 212 Starlet Bench-Top Portable Cryostat Manual

 **MADE IN BRITAIN**

**Bright**  
Instruments

# Contents

<b>SAFETY WARNINGS</b>	4	<b>1 INTRODUCTION</b>	10	<b>2 OPERATING INSTRUCTIONS</b>	12
Low temperature	4	<b>1.1 Receipt of Product</b>	10	<b>2.1 Control Panels</b>	12
Knives / blades	5	1.1.1 Receipt and unpacking	10	2.1.1 Mains switch	12
		1.1.2 Receipt	10	2.1.2 Defrost clock	12
<b>SAFETY INFORMATION</b>	6	1.1.3 Unpacking	10	2.1.3 Chamber temperature	12
Consumer protection	6	<b>1.2 Assembly &amp; Installation</b>	10	2.1.4 Defrost switch	12
Electrical	6	1.2.1 Fitting hand wheel	10	2.1.5 Quick freezer temperature	12
Mechanical	6	1.2.2 Installation of accessories	10	<b>2.2 Microtome Controls</b>	13
Operation	7	1.2.3 Insulating plug	11	2.2.1 Blade guard	13
Accessories	7	1.2.4 Positioning	11	2.2.2 Blade holder	13
UV light power unit (when supplied)	7	<b>1.3 Electrical Connections</b>	11	2.2.3 Blade angle	13
Decontamination procedures	7	1.3.1 Settling	11	2.2.4 Coarse advance control	12
		1.3.2 Electrical requirements	11	2.2.5 Section thickness control	14
<b>WARRANTY</b>	9	1.3.4 Switching on	11	2.2.6 Object holder	14

## Contents Cont.

<b>3</b>	<b>ANTI-ROLL ASSEMBLY</b>	15	<b>6</b>	<b>FROZEN SECTIONING: PROBLEM SOLVING GUIDE</b>	22	<b>ACCESSORIES &amp; CONSUMABLES</b>	25
3.1	Parallel adjustment	15				<b>MATERIAL SAFETY DATA SHEETS</b>	26
3.2	Height adjustment	15	<b>6.1</b>	<b>Checklist</b>	22	Cryo-M-Bed 53581	27
3.3	Magnaplate anti-roll plate	15	6.1.1	Specimen	22	Cryospray 57713	28
<b>4</b>	<b>CUTTING &amp; COLLECTING SECTIONS</b>	16	6.1.2	Blade check	22	Low Temperature Oil 57491	34
4.1	Trimming	16	6.1.3	Anti-roll plate	22	<b>REFERENCES &amp; DRAWINGS</b>	36
4.2	Section cutting	16	<b>6.2</b>	<b>Intermittent failure to cut</b>	22	Figure A. Quick Freezer Bar	37
<b>5</b>	<b>GENERAL MAINTENANCE</b>	17	<b>6.3</b>	<b>Sections crumbling/not forming</b>	22	Figure 1. Blade Holder	38
5.1	Daily Care	17	<b>6.4</b>	<b>Excessive compressions of sections</b>	22	Figure 2. Blade Angle	39
5.2	Automatic Deforst Cycle	17	<b>6.5</b>	<b>Uneven thickness across section</b>	23	Figure 3. Blade Angle Adjustment	39
5.3	Total Defrosting	18	<b>6.6</b>	<b>Vertical score marks on section</b>	23	Figure 4. Coarse Advance Control	40
5.4	Operating in Extreme Conditions	18	<b>6.7</b>	<b>Sections Curling</b>	23	Figure 5. Section Thickness Control	40
5.5	Service & Repairs	19	6.7.1	Sections curl over anti-roll plate	23	Figure 10. Trimming	41
<b>5.6</b>	<b>Decontamination</b>	20	6.7.2	Sections curl under anti-roll plate	23	Figure 11. Trimming	41
5.6.1	Formaldehyde decontamination	20	6.7.3	Sections curl under and stick to anti-roll plate	23	Figure 15. Pawl Assembly	42
5.6.2	Virkon decontamination	20	6.7.4	Sections curl after lifting anti-roll plate	23	Figure 16. Pawl Adjustment Rotary Handwheel Diagram	42
			<b>6.8</b>	<b>Sections fail to flatten and pass down blade</b>	23	DWG: 136026-01	44
			<b>6.9</b>	<b>Cutting Temperatures</b>	23		
			6.9.1	Fresh, unfixed tissue	23		
			6.9.2	Fixed tissue	23		
<b>7</b>	<b>SPECIFICATIONS</b>	24					



## **SAFETY WARNING**

**Low temperatures are present in this equipment. Extreme care should be taken.**

**DO NOT let bare skin come into contact with metal surfaces.**



## **SAFETY WARNING**

**Extremely sharp knives/blades.  
Use knife/blade guards at all times.  
Use correct tools for removal and insertion of knives/blades.**

**DO NOT leave knives/blades laying around.  
Place knives/blades not in use, into box/wallet provided.**

# Safety Information

## CONSUMER PROTECTION

The Consumer Protection Act 1987 Part 1, refers to Product Liability. This legislation was issued as a direct result of an EC Directive to all member states and has been in force with effect from 01 March 1988.

Bright Instrument Company Limited, ever mindful of the need to ensure that their products are not subject to misuse and/or incorrect handling, have made it their aim to communicate any possible dangers to their customers.

Whilst Bright Instrument Company Limited markets products manufactured to the highest safety standards, it is in the interest of the purchaser that he is aware of the resultant dangers of misuse and/or incorrect handling of these products.

Your attention is therefore drawn to the following precautions:

## ELECTRICAL

**a. Warnings** - A warning notice is fixed to the instrument stating that it should be disconnected from the power supply before removing the panels. This warning should be strictly observed. This cryostat is fitted with an in line mains filter which may affect portable appliance test results.

**b. Fuses** - Fuse ratings are clearly indicated on all fuse panels adjacent to the fuse holder. If and when replacement is necessary, the correct fuse rating must be adhered to.

**c. Earthing (Grounding)** - A protective earth terminal is fitted, and must be used in all two wire installations.

## MECHANICAL

Microtome knives can be hazardous in the laboratory. Personnel should be made aware of the dangers and observe the following warnings:

**a. Do not** leave the microtome unattended with an exposed knife in position. Remove the knife, or cover it with the guards provided.

**b. Do not** leave knives lying around. Place knives that are not in use in their boxes.

**c. Do not** carry knives unless secure in the box provided.

**d. Do not** clean the knife along its length. Wipe from the back edge of the cutting edge.

**e. Remember** that even used knives are dangerous – they are still sharp and may have been used to cut potentially infectious specimens.

**f. Dispose** of used knives with the same care as other sharp objects. **On no account** should used knives be placed in waste bins.

# Safety Information Cont.

## OPERATION

When placing object holders in the microtome, when orientating, manipulating or in any way placing fingers in a position above the knife edge – ensure that the hand wheel is locked and knife guards are in position.

Parts of this instrument may attain temperatures as low as minus 55°C. It is important to avoid allowing bare skin to touch such cold surfaces – when in doubt, wear gloves. Avoid touching the knife – it is cold as well as sharp! **ALWAYS** use knife guards

## ACCESSORIES

Fluids supplied as accessories with Bright Instruments, such as Cryospray 134, Cryo-M-Bed and microtome oil, are strictly for laboratory use only. They should not be taken by mouth and precautions afforded to other laboratory chemicals should be adhered to. Please refer to the material safety data information.

Care must be taken when using Cryospray 134. The risk of creating an aerosol of potentially infectious tissue particles must be borne in mind.

All communications should be direct to our Quality Assurance Department and will be acknowledged.

## UV LIGHT POWER UNIT (WHEN SUPPLIED)

This switchable power output provides an electrical supply for the optional UV light unit.

**WARNING:** The UV lamps emit short wavelength UV (UVC) radiation, which is potentially harmful to skin and eyes, and therefore adequate safety precautions must be taken.

It is a condition of the supply of this option that you accept the responsibility of ensuring that users are aware of this situation.

## DECONTAMINATION PROCEDURES

**Cryostats & Ultra Low Temperature Freezing Units:** If decontamination is required carry out the standard procedures as practised in your laboratory. It is the responsibility of the customer to use a decontamination procedure appropriate to his/her work. The following decontamination method is as recommended in the 'Code of Practise for the Prevention of Infection in Clinical Laboratories and Post-mortem Rooms', ISBN 0 11 320464 7.

- a. Bring the cryostat to room temperature.
- b. Place 50-100ml of formalin BP in a flat dish inside the chamber. Close the window.
- c. Leave for at least 24 hours, preferably 48 hours.
- d. Open the window and place a beaker containing 10ml of ammonia SG.880 in the chamber. Close the window.
- e. Leave for one hour. The cryostat is now decontaminated.essential that it be decontaminated.

# Safety Information Cont.

## DECONTAMINATION PROCEDURES CONT.

**Microtomes:** If decontamination is required carry out the standard procedures as practised in your laboratory. It is the responsibility of the customer to use a decontamination procedure appropriate to his/her work.

**Microtomes Knives:** If decontamination is required carry out the standard procedures as practised in your laboratory. It is the responsibility of the customer to use a decontamination procedure appropriate to his/her work.

For further information regarding alternative decontamination procedures please refer to 'Safe Working and the Prevention of Infection in Clinical Laboratories', ISBN 0 11 885446 1.



# Warranty

i. The Seller 's products are carefully inspected and submitted to its standard tests.

ii. The Seller warrants all its products to be free from defects in workmanship and materials under normal conditions of use and service provided always:

a. That if any of the goods so manufactured is alleged to be defective in workmanship and material and is returned carriage paid, and protected against damage in transit to the Seller's works at Huntingdon within 12 months from the date of despatch and if after examination by the Seller that goods or part of them are found to be so defective then the Seller will repair or replace them free of charge and will return them to the Buyer, carriage paid.

b. Where any part of the goods manufactured by the Seller is repaired or replaced under the terms of the foregoing warranty, such warranty shall thereafter be limited to a period of six months from the date when the goods shall have been re-delivered to the Buyer.

c. This warranty does not apply to any defects caused by wear and tear, incorrect installation abnormal conditions of working, accident, misuse or neglect.

d. That save as in this clause herein before expressed, the Seller shall not be under any liability for negligence or otherwise in respect of defects in goods delivered or for any injury, damage or loss resulting from such defects and the Seller's liability under this clause shall be in lieu of any warranty or condition implied by law as to the quality or fitness for any particular purpose of such goods.

e. This warranty is expressly in lieu of all other warranties, guarantees or liabilities expressed or implied by any of the Seller's Representatives or Agents.

Please see our separate Product Warranty sheet for deliveries to the mainland UK.

**WARNING:** Before proceeding to Operating Instructions, ensure you are familiar with the contents of the pages marked 'Safety Information'. This instrument must only be used by competent persons.

# 1. Introduction

## 1.1 RECEIPT OF PRODUCT

### 1.1.1 RECEIPT AND UNPACKING

This instrument received a final test and inspection prior to despatch from the factory. The following instructions are given for the re-assembly of the instrument, adjustments and its correct use. If the instrument is received before preparations for installation are completed. It should be stored in a clean, dry place and not exposed to dirty or damp conditions.

### 1.1.2 RECEIPT

Immediately upon receipt of the instrument, make a careful examination for evidence of damage encountered in transit. If any damage is found or suspected, notify both the carrier and Bright Instrument Company Limited immediately.

### 1.1.3 UNPACKING

All packing must be carefully removed and parts checked against the enclosed packing list. If any damage or discrepancy is noted, please inform our agent/distributor or Bright Instrument Company Limited immediately.

## 1.2 ASSEMBLY & INSTALLATION

### 1.2.1 FITTING HAND WHEEL (MODELS WITH HAND WHEEL ONLY)

Push the hand wheel over the shaft on the right side of the cabinet. Ensure pin on shaft engages slot in centre of hand wheel, press firmly home then fit centre screw.

### 1.2.2 INSTALLATION OF THE MICROTOME (ALWAYS INSTALLED ON INITIAL DESPATCH)

The microtome is supplied already installed in the chamber, carefully remove the packing from around the microtome and the anti-roll

plate and turn the plate so it faces the blade holder. Note that the metal plate at the back of the chamber is held in place with adhesive tape during transit – remove and discard the tape.

Fit the stainless-steel shelf to the sides of the chamber on the two studs provided. Place the black quick freezer bar in position at the front right side of the chamber and locate with lock pin as shown below.

Refer to Figure A.

The freezer bar can be used to freeze specimens to the specimen holders.

If the Starlet is the lever operated version, screw the lever into position on the right side of the microtome, using the black knob on.

# 1. Introduction Cont.

## 1.2 ASSEMBLY & INSTALLATION CONT.

### 1.2.3 INSULATING PLUG

The insulated plug should be fitted into position in the top of the chamber at all times, except when the cryostat is actually in use.

### 1.2.4 POSITIONING

As free air flow around the cryostat is essential, take care that the vents at the sides of the cryostat are not restricted.

## 1.3 ELECTRICAL CONNECTIONS

### 1.3.1 SETTING

During transit the oil in the compressor will have been subject to movement, so it is important to let the instrument settle before switching on. We recommend the instrument is left standing for at least eight hours, and preferably overnight, before switching on.

### 1.3.2 ELECTRICAL REQUIREMENTS

The supply cord of the instrument should be connected to any ordinary electrical outlet (minimum 13 amps for 220/240v or 20 amps for 110/115v) a 13 amp or 20 amp fuse should be incorporated in the line. Check the voltage stamped on the name plate, located on the back of the cabinet tallies, with your supply.

The connections are:

Brown - Positive (live)

Blue - Negative (neutral)

Yellow/Green - Earth (ground)

### 1.3.3 SWITCHING ON

After settling, switch on the mains (Section 2.1.1) Initially the LEDS displays will flash for a few seconds. Once the displays are constant, the required chamber temperature can be set (Section 2.1.3)

## 2. Operating Instructions

### 2.1 CONTROL PANELS

#### 2.1.1 MAINS SWITCH

This is located on the rear panel. It is recommended that the cryostat is left running even if it is not being used regularly.

#### 2.1.2 DEFROST CLOCK

Set the clock on the rear panel to the actual time by turning the clear plastic disc with your finger. [See Section 3.2 for additional information on defrosting.]

#### 2.1.3 CHAMBER TEMPERATURE

This is located on the top control panel. See Fig B

To set chamber temperature, press and release Set button, then press Up or Down buttons until desired temperature is set. After 5 seconds the actual chamber temperature will show.

To review set temperature at any time press and release Set button.

**WARNING:** Do not hold the Set button down for more than 6 seconds as the control will go into a diagnostic/calibration mode.

If the diagnostic/calibration mode is selected in error, take the following steps:

- a. If Up or Down have not been pressed (ie: no new parameters have been entered), simply leave for 20 seconds. Display will revert to normal.
- b. If new parameters have been selected contact Bright Instrument Company Limited or your local representative for advice.

#### 2.1.4 DEFROST SWITCH

When on, a defrost heater is activated during the defrost cycle. (Section 3.2).

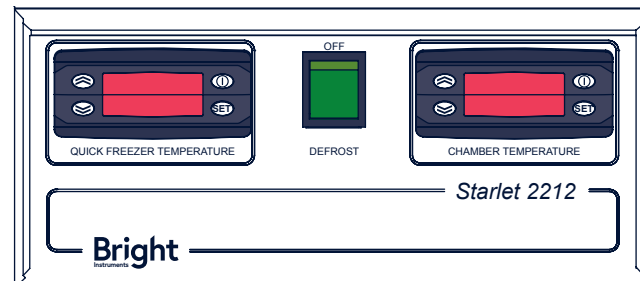

**PLEASE NOTE:** The defrost switch should remain on all the time that the cryostat is switched on. This is because once every 24 hours it is necessary to heat the evaporator fins to melt the frost on them, to keep the refrigeration system running efficiently. During the heating cycle a small amount of water might be released from the drain at the rear of the cryostat and a small container should be used to catch this water.

#### 2.1.5 QUICK FREEZER TEMPERATURE

Also located on the top control panel, this constantly displays the temperature of the quick freezer bar.

## 2. Operating Instructions Cont.

### 2.2 MICROTOME CONTROLS

This is located on the rear panel. It is recommended that the cryostat is left running even if it is not being used regularly.

#### 2.2.1 BLADE GUARD

This should be in position against the blade at all times when a blade is fitted, except when sections are being cut.

#### 2.2.2 BLADE HOLDER

Refer to Figure 1.

The blade is held in position by a series of powerful magnets located on the blade holder.

Before positioning the blade, it is important to ensure that the holder is completely free of ice, frost or debris that could prevent the blade from seating perfectly. A dirty blade holder will almost certainly cause blade vibration and bad sectioning.

Frost and ice can be removed from the holder by scraping it with a wooden or plastic scraper or wiping it with a cloth dampened with alcohol.

After cleaning, be sure to remove all traces of alcohol by wiping it with a dry cloth.

Take a new blade from the dispenser and remove the grease with solvent.

To position the blade, place it in the slot on the left side of the blade holder, then slide it in, keeping it in place on the ledge. When one of the holes in the blade appears, top sliding by hand. Locate the small circular tip of the blade handling device in the hole and slide the blade into position. To obtain maximum use of the blade, slide it to a new position when the edge has dulled. After half the blade has been used in this way, remove it as described below, reverse and re-position it.

To remove a used blade, hook the blade handling device above the dull edge centrally over the hole. Press the lower round projection of the device into the hole in the blade. Then slide the blade up and away from the magnetic holder.

The blade may now be detached from the device and safely disposed of. If the blade has been used only at one end, it may be reversed and refitted as described above.

#### 2.2.3 BLADE ANGLE

Refer to Figure 2 & 3.

The blade holder is clamped in position against a cam by means of the knob (39).

To adjust the blade angle, slacken the cam lock screw (25) and reposition the cam by moving the knife angle adjuster (24), the angle is indicated on the scale.

Re-tighten lock screws (25) and knob (39) securely.

After adjusting the angle, it may be necessary to re-position the specimen.

#### 2.2.4 COARSE ADVANCE CONTROL

Refer to Figure 4.

The ratchet wheel (14) is used for manually moving the specimen forwards or backwards.

Before moving the wheel, disengage the pawl (17) by pushing the lever to the left.

## 2. Operating Instructions Cont.

### 2.2 MICROTOME CONTROLS CONT.

#### 2.2.5 SECTION THICKNESS CONTROL

Refer to Figure 5.

Set the micron indexing dial (28) to the desired section thickness.

**IMPORTANT:** Always push the operating lever/hand wheel down slightly before changing thickness setting.

#### 2.2.6 OBJECT HOLDER

First apply a coating of embedding compound to the top surface of the object holder, making sure that the temperature of the object holder is above zero otherwise the embedding compound will not freeze on it properly.

Tissue samples are then frozen onto the object holder (34) by placing the object holder into a hole in the quick freezer bar,

Figure 6.

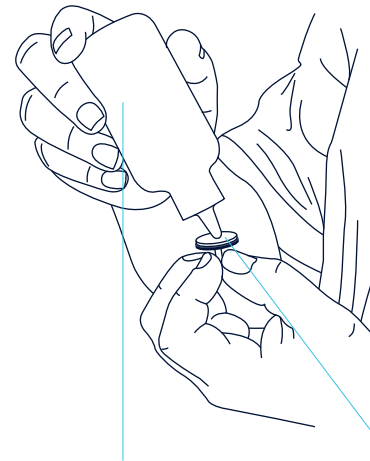

Bright Instruments  
Cryo-M-Bed

Figure 7.

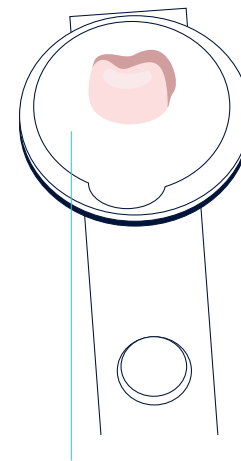

Object Holder (34)

before inserting in the carrier (head)(12) and tightening the clamp screw (20)

Figure 8.

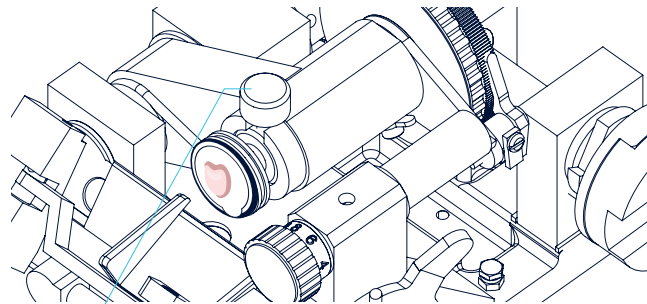

Clamp Screw

### 3. Anti-Roll Plate Assembly

The Anti-roll Plate (ARP) is probably the most important accessory to obtaining good sections. Its correct adjustment and maintenance are essential.

The ARP is set ready to use, but if adjustment is necessary the following directions should be followed:

Figure 9.

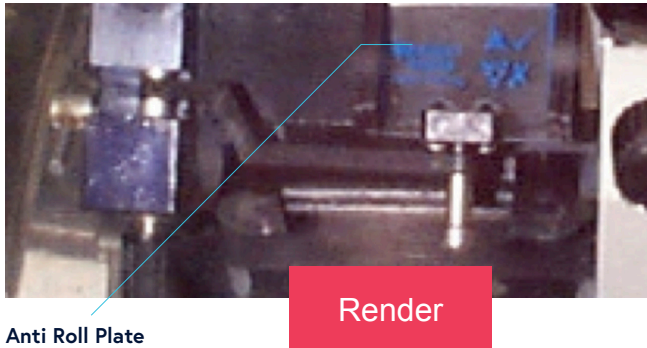

#### 3.1 PARALLEL ADJUSTMENT

The top edge of the ARP must be parallel to the blade. It can be adjusted by slightly loosening screws (89) and moving the ARP into position. Then tighten the screws.

#### 3.2 HEIGHT ADJUSTMENT

The top edge of the ARP should be just above the blade edge. If it is too low, the section will curl up and fail to pass between the blade edge and ARP.

To adjust the height of the ARP turn screw (84)

Upward adjustment can be made with the ARP against the blade; downward adjustment must be made with it away from the blade. If the

ARP is moved downwards against the blade the spacing registers will be cut away and the AR will be damaged.

**NOTE:** that the surfaces of the ARP and the blade must be clean and free of grease, frost or debris.

#### 3.3 MAGNAPLATE ANTI-ROLL PLATE

The Magnaplate anti-roll plate can be used as an alternative to the fixed anti-roll plate.

Figure 12a.



Figure 12b.

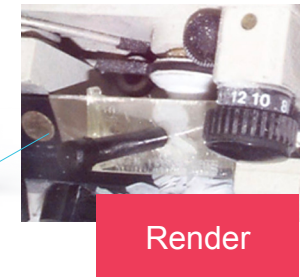

## 4. Cutting And Collecting Sections

### 4.1 TRIMMING

Refer to Figures 10 & 11.

- a. Disengage the pawl (17) by pushing the lever to the left.
- b. Turn the ratchet wheel (14) anticlockwise; the carrier moves back away from the blade.
- c. Place the specimen on its object holder (34) in the carrier (head) (12) and tighten the clamp screw (20).
- d. Bring the specimen down by means of the actuating handle/hand wheel (30) and turn the ratchet wheel (14) clockwise until the specimen reaches the blade.
- e. Re-engage the pawl (17) by pushing the lever to the right.
- f. Set the micron indexing dial (28) to 12 $\mu$ m.
- g. Move the handle down and up, (or the hand wheel round), until satisfactory sections are cut.
- h. Clean the blade surface using the bristle brush with an upward motion.

### 4.2 SECTION CUTTING

- a. Set the micron indexing dial (28) to the desired thickness.

**IMPORTANT:** Always push the operating lever/hand wheel down slightly before changing thickness setting.

- b. Swing the anti-roll plate into position.
- c. Actuate the operating lever / hand wheel; a slow stroke generally gives good results. Experiment to find the most suitable speed.

Figure 12.



- d. After cutting an acceptable section, lock the specimen at the bottom by using the hand wheel lock, or by pushing the lever back.

- e. Swing the anti-roll plate carefully aside.

- f. Take a glass slide from the ambient temperature of the laboratory and bring it up gently to the section. The section should move on to the slide.

**NOTE:** Foreign matter – fragments of previous sections – ice or a film of grease on the blade or anti-roll plate – will cause sufficient friction to prevent sections from slipping down the blade surface freely. The blade should be kept clean by means of the bristle brush. The bristle brush should frequently be cleaned in acetone or chloroform and occasionally well-washed in detergent. A coating of ice on the back of the blade will damage the exposed surface of the tissue block.

**NOTE:** When the instrument is fitted with 4-24 $\mu$ m feed range (2212-019) then the scale is doubled. ie: Setting of 8 $\mu$ m, Actual thickness is 16 $\mu$ m.



## 5. General Maintenance

### 5.1 DAILY CARE

All major parts are self-lubricating. However, certain other parts and the screw threads are not, and should be kept lubricated with the special low temperature grease provided.

Clean up debris from chamber. If necessary, scrape any frozen debris from the freezer area.

Every few months remove the back panel and clear any dust and lint which has accumulated on the fins of the condenser. This is best carried out with a vacuum cleaner suction nozzle, using a brush to clear the matter from the crevices.

### 5.2 AUTOMATIC DEFROST CYCLE

This clock sets the time required for routine defrosting. During the defrost cycle the clock switches off the refrigeration unit and activates a low power heater (if switched on) which clears frost from the cooling fins. The defrost clock should be set so that it initiates the defrost at night, and the defrost duration is sufficient to clear the cooling fins without the rest of the chamber rising above 0°C.

Figure 13.



Set the analogue clock to the actual time by turning the clear plastic disc with your finger.

**NB:** This is a 24 hour clock. Check that the small black arrow is aligned with the correct time, i.e.: a.m. or p.m.

The defrost time is set in the factory to start at midnight for 30 minutes, but may be altered by moving the pins which are around the edge of the clock face. If the time already set provides inadequate defrosting, it is recommended that a second 30 minute cycle is programmed to operate several hours later (eg: 12 midnight and 6am)

**IMPORTANT:** DO NOT increase the defrost time above 30 minutes, as the microtome and chamber may warm up above 0°C causing pools of water to form and subsequently freeze.

In conditions of high humidity some experimentation may be required to obtain optimal defrosting (section 3.4)

There is an override switch on the defrost clock: turning the small black button switches the defrost cycle on or off.

## 5. General Maintenance Cont.

### 5.3 TOTAL DEFROSTING

It will be necessary to periodically defrost the entire cryostat to carry out cleaning and/or other procedures. The frequency of this total defrosting will depend on how heavily the cryostat is used; it may be as often as daily but is commonly once a month.

To carry out a total defrost:

- a. Switch off the cryostat
- b. Remove the storage shelf and quick freezer bar (reversal of installation – Section 1.1.3)
- c. Remove the microtome as follows:

**Hand wheel version:** Press down on the specimen carrier to take up the spring tension. With the other hand press the drive shaft coupler to the right and rotate it forwards (clockwise) to lock it. Now pull the microtome forwards, then lift it out of the chamber.

Figure 14.

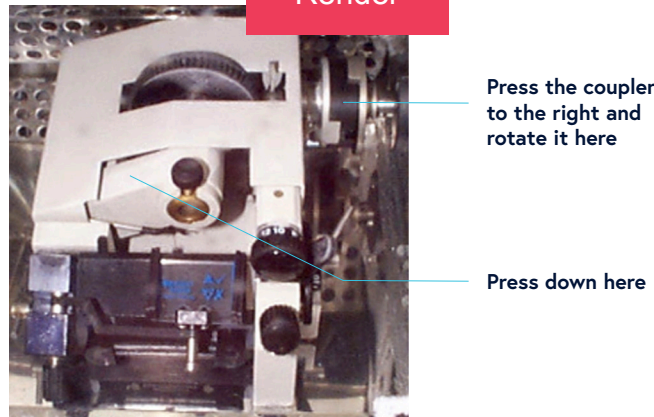

**Lever version:** Simply pull the microtome forward and lift it out of the chamber.

- d. Remove the cover from the microtome and allow it to warm to room temperature and dry off completely, then lubricate the visible screw threads with the low temperature grease supplied.
- e. Clean the chamber and dry it off.
- f. See notes on Decontamination (section 3.6).

g. Re-installation of the microtome is the reverse of removal. With the hand wheel version ensure the hand wheel is in the correct position before engaging coupling, and check that the coupling fully engages by rocking the hand wheel.

### 5.4 OPERATING IN EXTREME CONDITIONS

- a. The refrigeration system used in Bright cryostats is highly efficient and will cope well with high ambient temperatures. However, where conditions of high humidity exist, it may be necessary to adjust the automatic defrost cycle in order to ensure that the cooling coils remain frost-free.
- b. It is recommended that additional defrost cycles are initiated at convenient times (eg: 18.00, 06.00 hours).
- c. This is done by pressing in the appropriate pins on the clock to give two further thirty minute defrosts.
- d. Do not extend the defrost cycle time beyond thirty minutes, as this could cause the entire chamber to warm up above 0°C.

## 5. General Maintenance Cont.

### 5.5 SERVICING & REPAIRS

In the event of a breakdown a qualified person should be called. Refrigeration problems are likely to be rare, and will normally be dealt with by your local refrigeration specialist. For electrical and mechanical problems contact either your local agent / distributor or Bright Instrument Company Limited.

Please provide the following information:

- Model and serial number  
(ID plate on rear panel)
- Date of Installation
- Nature of Fault

The following tasks can be carried out by competent personnel:

#### Changing fuses:

On the rear panel of the cabinet are a number of fuse holders. Determine which fuse is blown and replace it with one of exactly the same type and rating.

#### Replacing the Pawl and Spring:

Refer to Figures 15 & 16.

- Remove the microtome from the cryostat and take off its cover.
- Locate pawl (17) shown on Figs.3 & 4
- Remove pawl spring locating screw, spring and backing plate (97, 19, 73)
- Replace new spring, backing plate and locating screw.
- Check to see if pawl indexes the ratchet wheel correctly:

Turn the ratchet wheel clockwise, looking at and listening for positive pawl indexing: operating the microtome at 12 $\mu$ m setting: check that the ratchet wheel does not index on the down strike.

- Set pawl in the rewind position.

- Loosen the lock screw (18)

- Set the gap from ratchet wheel to pawl point to approximately 2mm.

- Tighten the lock screw.

- Repeat step 'e'.

- When you have finished, replace the cover, put the microtome back into the cryostat and check it under refrigerated conditions.

#### Calibrating the Microtome:

- Remove the microtome from the cryostat and take off its cover.

- Set micron indexing dial (28) to 12 $\mu$ m with pawl disengaged (Fig.1)

- The roll pin (98) on pawl arm (13) should be approximately 1mm away from index cam (27) if otherwise, adjust pawl stop/cap head screw (48/72) to correct the gap.

## 5. General Maintenance Cont.

### 5.5 SERVICING & REPAIRS CONT.

#### Calibrating the Microtome (Cont.):

d. Engage the pawl. Operate one complete cutting and return cycle. Then slowly do a downward cutting stroke observing pawl movement (clicks) in and out of teeth on ratchet wheel (14), 1 click = 2µm. If otherwise, adjust screw (88), clockwise for fewer clicks.

**NOTE:** Before adjusting screw (88), loosen the locking nut (106) beneath (88) and tighten after each adjustment.

e. When you have finished, replace cover, put the microtome back into the cryostat and check it under refrigerated conditions. It may be necessary to alter the calibration once the microtome is cold, particularly if a hand wheel is fitted.

### 5.6 DECONTAMINATION

It is the responsibility of the user to ensure that a decontamination procedure is employed which is appropriate to the nature of the work carried out.

The cryostat chamber, freezer assembly and accessible parts of the microtome are constructed of corrosion-resistant materials, and the following decontamination procedures can be used. Hypochlorite (bleach) solutions are corrosive to many metals and should be avoided.

#### 5.6.1 FORMALDEHYDE DECONTAMINATION

This method is recommended in the Howie Code on the prevention of infection in medical laboratories and more recently in the "Code of Practice for the Prevention of Infection in Clinical Laboratories and Post-mortem Rooms", ISBN 0 11 320464 7

- a. Defrost the cryostat completely (after removing knife)
- b. Place 50ml of formalin BP in a flat dish in the cabinet. Fit the insulating plug.
- c. Leave for at least 24 hours and preferably 48 hours.
- d. Remove the insulating plug briefly and place a beaker containing 10ml of ammonia SG.880 in the chamber.
- e. Leave for 1 hour. The cryostat is then ready for cleaning.

#### 5.6.2 VIRKON DECONTAMINATION

'Virkon' is a virucidal disinfectant made by Antec International and widely used in microbiological and clinical departments.

- a. Defrost the cryostat completely.
- b. Remove the microtome (Section 3.3.3)

## 5. General Maintenance Cont.

### 5.6.2 VIRKON DECONTAMINATION CONT.

c. Make up Virkon solution according to the manufacturer's instructions.

d. Wipe round the cryostat chamber with a cloth or paper towel wetted with Virkon solution. Ensure all debris is collected and all surfaces have ample contact with the solution.

e. Wipe over again with clean water.

**NB:** DO NOT use excessive quantities of Virkon solution or water during this procedure.

f. Carry out a similar procedure on the microtome.

g. Ensure microtome and chamber are dry.

h. Apply low temperature grease sparingly to screw threads and re-install microtome in the chamber.

i. The cryostat is now ready to be switched back on.

## 6. Frozen Sectioning: Problem Solving Guide

Cutting good frozen sections requires skill and practice, and some tissues are particularly difficult. In all cases the quality of the result depends on a number of factors.

The notes which follow deal with the more commonly encountered difficulties and suggest a systematic approach to problem solving.

### 6.1 CHECK LIST

First check all the basic factors:

#### 6.1.1 SPECIMEN

- a. Was it frozen badly?
- b. Has it equilibrated to chamber temperature?
- c. Has it become loose on the specimen holder?
- d. Is the specimen holder tightly clamped?
- e. Has the specimen dehydrated?

#### 6.1.2 BLADE

- a. Has it become dull?
- b. Is it nicked or chipped?
- c. Is the blade tilt angle incorrect?
- d. Is the blade loose?
- e. Is there a build-up of frost or debris on the blade?

#### 6.1.3 ANTI-ROLL PLATE

- a. Is it set too high/low?
- b. Is it parallel to the blade?
- c. Is it frosted / too warm?
- d. Is it damaged? (section 2.3)

### 6.2 INTERMITTENT FAILURE TO CUT

- a. Blade not sharp enough?
- b. Blade tilt angle too high / low?
- c. Specimen loose on holder?
- d. Clamping screw too loose?
- e. Cutting temperatures too warm / cold?
- f. Anti-roll plate adjusted too high?
- g. Tissue expansion due to block warming up?

### 6.3 SECTIONS CRUMBLING OR NOT FORMING

- a. Freezing technique too slow?
- b. Cutting temperatures too warm / cold?
- c. Specimen not equilibrated to chamber temperature?
- d. Specimen dehydrated?
- e. Blade not sharp enough?
- f. Cutting motion too fast or uneven?
- g. Blade tilt angle too high / low?

### 6.4 EXCESSIVE COMPRESSION OF SECTIONS

- a. Blade not sharp enough?
- b. Blade tilt angle too high?
- c. Blade surfaces frosted or debris build up?
- d. Anti-roll plate frosted, too warm or incorrectly adjusted?
- e. Freezing technique too slow?
- f. Cutting temperature too warm?

## 6. Frozen Sectioning: Problem Solving Guide Cont.

### 6.5 UNEVEN THICKNESS ACROSS SECTION

- a. Specimen loose in holder.
- a. Clamping screw too loose.
- a. Blade not sharp enough.
- a. Blade edge too thin.
- a. Cutting motion uneven.

### 6.6 VERTICAL SCORE MARKS ON SECTIONS

- a. Blade edge nicked or chipped?
- b. Blade faces have built up debris or frost.
- c. Anti-roll plate edge damaged?
- d. Anti-roll plate surface has debris or frost built up.
- e. Tissue contains hard, fine particles (eg: bone fragments).

### 6.7 SECTIONS CURLING

#### 6.7.1 SECTIONS CURL OVER ROLL PLATE

- a. Anti-roll plate too low?

#### 6.7.2 SECTIONS CURL UNDER ANTI-ROLL PLATE

- a. Anti-roll plate at too large an angle to blade

#### 6.7.3 SECTIONS CURL UNDER AND STICK TO ROLL PLATE

- a. Anti-roll plate too warm, greasy

#### 6.7.4 SECTIONS CURL AFTER LIFTING ROLL PLATE

- a. Movement too quick, delay in collecting sections

### 6.8 SECTIONS FAIL TO FLATTEN AND PASS DOWN BLADE

- a. Anti-roll plate too warm, greasy or misaligned
- b. Blade surface has built up frost or debris or is too warm.

### 6.9 CUTTING TEMPERATURES

Standard textbooks on histological technique give table of recommended cutting temperatures for different tissues. However, in most cases the following guidelines will prove adequate.

#### **Fresh, infixed tissue**

Most soft tissues will cut at  $-18^{\circ}\text{C}$  to  $-20^{\circ}\text{C}$ . fatty tissue such as breast lumps will need lower temperatures,  $-25^{\circ}\text{C}$  or colder. Brain and spinal cord cut best at warmer temperatures, eg;  $-12^{\circ}\text{C}$

#### **Fixed tissue**

Differences between tissues are much reduced after fixation. Cutting temperatures around  $-10^{\circ}\text{C}$  to  $-15^{\circ}\text{C}$  are recommended, but some experimenting may be required. Ensure fixative is rinsed off tissue before freezing.

# 7. Specifications

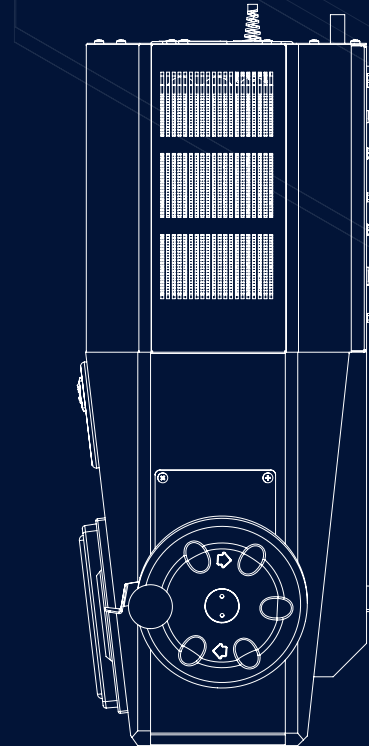
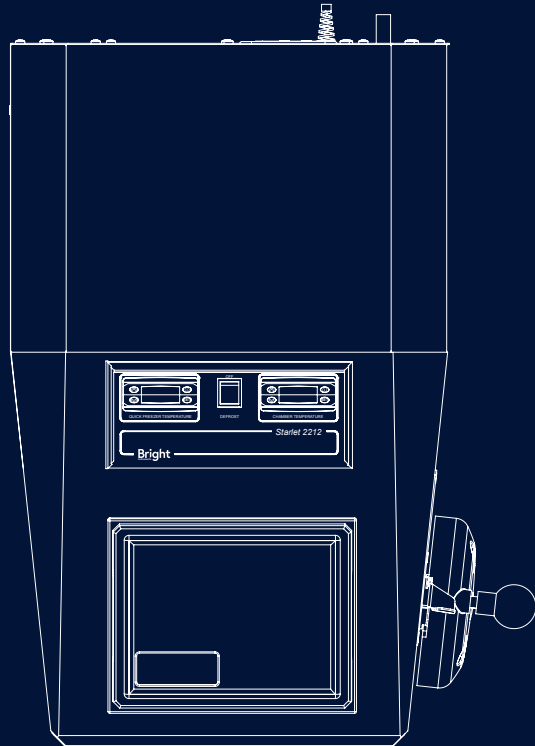
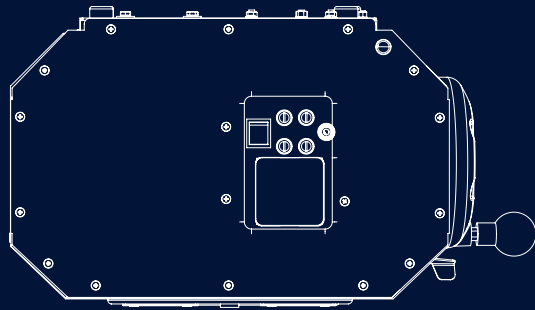

<b>Compressor Type</b>	1 x 3.86cc displacement
<b>Refrigerant</b>	HFC-compliant refrigerants
<b>Cooling Power</b>	125watt at -35°C
<b>Lowest Set Temperature</b>	Ambient to -35°C with automatic programmable defrost with manual override and digital display. Detachable cold storage bar.
<b>Cabinet</b>	ABS Polymer and Stelvetite Polymer coated steel - scratch, solvent and detergent resistant.
<b>Cutting Stroke</b>	30mm
<b>Maximum Specimen Size</b>	22mm diameter
<b>Total Feed Range</b>	10mm
<b>Knife Holder</b>	Magnacut blade holder with long-life disposable blades and integral anti-roll system
<b>Object Holders</b>	22mm
<b>Specimen Orientation</b>	Adjustable tilt angle 0-12°
<b>Specimen Thickness Range</b>	2-12µm in 2µm increments 4-24µm optional
<b>Dimensions</b>	H315 x W465mm(min)/ 546mm(max) x D740mm
<b>Packing</b>	Net weight: 40kg Gross weight: 48kg Packing dimensions: H400 x W920 x D550mm Shipping volume: 0.20m3

Weights vary according to specification of instrument



# 2212 Starlet

## Order List 2021

PRODUCT	
Code	Description
2212-021	<b>Starlet 2212 Cryostat for 22/240V AC, 50/60Hz</b>  Complete with: <ul style="list-style-type: none"><li>• Single refrigeration system (-30 degree).</li><li>• Manual microtome with 2-12um feed.</li><li>• Magnacut knife holder with ten long life disposable blades.</li><li>• Magnaplate anti-roll plate system.</li><li>• Handwheel operation.</li><li>• Specimen quick freeze (-40 degree) with digital display.</li><li>• Programmable automatic defrost.</li></ul> Standard accessories include: <ul style="list-style-type: none"><li>• Anti-roll plate.</li><li>• 2 x object holders.</li><li>• Knife, cleaning brush.</li><li>• Detachable shelf.</li><li>• Debris tray.</li><li>• Blade removal tool.</li><li>• Spare set of fuses.</li><li>• Low temperature grease.</li><li>• **Cryospray freezing spray.</li><li>• Cryo-M-Bed embedding compound</li><li>• Insulated cover.</li><li>• Operating manual.</li></ul>
2212-022	<b>Starlet 2212 Cryostat (Same as 2212-021) for 110/120V AC, 60Hz</b>
2212-024	<b>Starlet 2212 Cryostat (Same as 2212-021) for 100V, 50/60Hz</b>

ACCESSORIES	
Code	Description
50894-3	Cryo block embedding mould, 22mm diameter.
50894-2	Cryo block embedding mould, 16mm diameter.
50894-1	Cryo block embedding mould, 10mm diameter.
50874	Orientating object holder, complete with stem.
50909	4-24 um feed screw ( in place of 2-12um feed screw).
50813*	Object holder, 22mm diameter.
50829	Easi-Set anti-roll plate.
52278*	Insulated night plug.
52281	Ultra violet night decontamination unit, consisting of night plug, power supply & germicidal lamp.
50848*	Detachable shelf.
57713-1*	Bright Cryospray 134, 300ml aerosol can.
57713	Bright Cryospray 134, 300ml aerosol can, carton of 12.
53581-1*	Bright Cryo-M-Bed, 120ml bottle.
53581	Bright Cryo-M-bed, 120ml bottle, carton of 6 bottles.
57355*	Low temperature grease, 5g net.
57344*	Knife cleaning brush.
57808	Anti static brush, 12mm.
50300-1*	Magnaplate anti-roll plate x3 & handle.
52727	Pack of 50 long life disposable Magnacut blades, C profile.
51564*	Blade removal tool.
53768	Replacement microtome only - Rotary operation.
53559	Spare fuse set for 2212-021 and 2212-001.
53560	Spare fuse set for 2212-022 and 2212-002.
53569	Spare fuse set for 2212-023 and 2212-003.

Office: **Bright Instruments LTD**  
Burnett House, Lakeview Court  
Ernie Business Park, Huntingdon  
Cambridgeshire, PE29 6UA

Telephone: +44 (0) 808 168 9697  
Web: [brightinstruments.com](http://brightinstruments.com)  
**MADE IN BRITAIN** 

\*Included in standard order | \*\*Not included in overseas orders. VAT not included - E & OE

**Bright**  
Instruments

# Material Safety Data Sheets

### 1. Cryo-M-Bed 53581 Product Information

<b>Trade/Type:</b>	Embedding Compound.
<b>Container:</b>	Disposable plastic bottles.
<b>Uses:</b>	Embedding compound for frozen tissue specimens.
<b>Description:</b>	Colourless viscous liquid.

### 2. Cryo-M-Bed 53581 Product Information

<b>Information on Ingredients:</b>	Blend of polyviol alcohol 217, thymol and water.	
<b>Physical and Chemical Properties:</b>	Colourless viscous liquid.	
<b>Stability and Reactivity:</b>	May react with oxidising materials.	
<b>Toxicological Information:</b>	No harmful effects if handled correctly. May give off toxic fumes in the case of fire.	
<b>Ecological Information:</b>	Degradable, miscible in all proportions.	
<b>Transport Information:</b>	No restrictions.	
<b>Hazards Identification:</b>	Skin:	Can cause skin irritation.
	Respiratory:	May cause difficulty in breathing if exposed to very high concentration.
	Ingest:	May be harmful by ingestion.
	Eyes:	Can cause Eye irritation.
<b>First Aid Procedures:</b>	Skin:	Wash thoroughly, with soap and water.
	Respiratory:	Move to fresh air.
	Ingest:	Rinse mouth out with water, in sever cases seek medical attention.
	Eyes:	Flush copiously for at least 15 minutes.
<b>Fire Fighting Measures:</b>	Hazards:	May cause toxic fumes.
	Equipment:	Water spray, foam, dry powder, CO <sub>2</sub> .
<b>Disposal Considerations:</b>	Bag and dispose of waste in accordance with local authority requirements.	
<b>Handling Storage:</b>	No special requirements.	
<b>Regulatory Information:</b>	None.	
<b>Accidental Release Measures:</b>	Absorb spillage on an inert absorbent, bag and arrange disposal. Wash area in water and detergent.	
<b>Exposure Controls:</b>	Skin:	Avoid contact.
	Respiratory:	Avoid very high concentrations.
	Ingest:	Do not eat, drink or smoke.
	Eyes:	Goggles should be worn.
	OES:	Not assigned (long term, 8 hour TWA).

# Cryospray 1234ze

## MATERIAL SAFETY DATA SHEET

### 1. Cryospray 1234ze Product Information

<b>Trade/Type:</b>	Bright Cryospray 1234ze Freezing Agent.
<b>Container:</b>	Aerosol.
<b>Uses:</b>	Rapid Freezing of tissue specimens to -52°C.
<b>Description:</b>	Gases under pressure, Liquefied gas.

### 2. Hazards Identification

<b>Classification of the substance or mixture:</b>	Classification according to Regulation (EC) No 1272/2008/EC (CLP/GHS):	Gases under pressure, Liquefied gas H280 Contains gas under pressure; may explode if heated.	
<b>Label Elements:</b>	<b>Labelling Pictograms:</b>		
	<b>Signal Word:</b>	Warning	
	<b>Hazard Statements:</b>	H280:	Contains gas under pressure; may explode if heated.
	<b>Precautionary Statements:</b>	P281:	Use personal protective equipment as required.
		P260:	Do not breathe dust/fumes/gas/mist/vapours/spray.
		P308 + P313:	If exposed or concerned: Get medical advice/attention.
		P410 + P403:	Protect from sunlight. Store in a well-ventilated place.
	<b>Potential Health Effects:</b>	<b>Skin:</b>	Rapid evaporation of the liquid may cause frostbite.
		<b>Eyes:</b>	May irritate eyes.
		<b>Ingestion:</b>	Unlikely route of exposure.
<b>Inhalation:</b>		Inhalation may cause central nervous system effects. Vapours may cause dizziness and drowsiness.	
<b>Chronic:</b>		None known.	
<b>General:</b>		Warning. Container under pressure.	
<b>Potential Environmental Effects:</b>	An environmental hazard cannot be excluded in the event of unprofessional handling or disposal.		

### 3. Composition / Information on ingredients

Substance or mixture:	CAS number:	29118-24-9
	EC Number (from EINECS):	471-480-0

### 4. First Aid Measures

General advice:	Show this safety data sheet to the doctor in attendance. Keep warm and in a quiet place.
Inhalation:	If inhaled, move to fresh air. Seek medical attention if irritation develops and persists.
Skin contact:	Rapid evaporation of the liquid may cause frostbite. If there is evidence of frostbite, bathe (do not rub) with lukewarm (not hot) water. If water is not available, cover with a clean, soft cloth or similar covering. Call a physician if irritation develops or persists.
Eye contact:	If eye irritation persists, consult a specialist.

### 5. Fire-fighting measures

Extinguishing media:	Show this safety data sheet to the doctor in attendance. Keep warm and in a quiet place.
Special hazards arising from the substance or mixture:	If inhaled, move to fresh air. Seek medical attention if irritation develops and persists.
Advice for fire fighters:	<b>Special protective equipment</b> Rapid evaporation of the liquid may cause frostbite. If there is evidence of frostbite, bathe (do not rub) with lukewarm (not hot) water. If water is not available, cover with a clean, soft cloth or similar covering. Call a physician if irritation develops or persists.
	<b>Further information</b> In the event of fire, cool tanks with water spray.

### 6. Accidental Release Measures

Personal precautions, protective equipment and emergency procedures:	Provide adequate ventilation. Vapours are heavier than air and can cause suffocation by reducing oxygen available for breathing. Avoid skin contact with leaking liquid (danger of frostbite). Use personal protective equipment. Keep people away from and upwind of spill/leak.
Environmental precautions:	Prevent further leakage or spillage if safe to do so. The product evaporates readily. Prevent spreading over a wide area e.g. by containment or oil barriers.
Methods for cleaning up:	Do not direct water spray at the point of leakage. Allow to evaporate.

### 7. Handling and Storage

Advice for safe handling:	Pressurized container: protect from sunlight and do not expose to temperatures exceeding 50°C. Do not pierce or burn, even after use. Do not burn. Exhaust ventilation at the object is necessary.
Advice on protection against fire and explosion:	Do not spray on a naked flame or any incandescent material. Keep away from direct sunlight. Fire or intense heat may cause violent rupture of packages. Vapours may form explosive mixtures with air. The product is not easily combustible.
Hygiene measures:	Avoid breathing vapours, mist or gas. Keep working clothes separately. Do not smoke.
Further information on storage conditions:	Keep containers tightly closed in a cool, well-ventilated place. Keep only in the original container at temperatures not exceeding 50°C. Keep away from direct sunlight.
Advice on common storage:	Do not store together with Oxidising agents.

## 8. Exposure controls / personal protection

Occupational exposure limits:	Components:	Trans-1,3,3,3-Tetrafluoroprop-1-ene		
	Basis:	Honeywell	Exceeding factor:	N/A
	Value type:	Time weighted average	Form of exposure:	N/A
	Control parameters:	800 ppm	Remarks:	We are not aware of any national exposure limit.
Occupational exposure controls:	The Personal Protective Equipment must be in accordance with EN standards: respirator EN 136, 140, 149; safety glasses EN 166; protective suit EN 340,463, 468, 943-1, 943-2; gloves EN 374; safety shoes EN-ISO 20345. The type of protective equipment must be selected according to the concentration and amount of the dangerous substance at the specific workplace. Avoid inhalation of vapour or mist.			
Environmental exposure controls:	Avoid breathing vapours, mist or gas. Keep working clothes separately. Do not smoke.			
Engineering measures:	Keep containers tightly closed in a cool, well-ventilated place. Keep only in the original container at temperatures not exceeding 50°C. Keep away from direct sunlight.			
Personal protective equipment:	Respiratory protection:	Remarks: In case of insufficient ventilation, wear suitable respiratory equipment. Wear a positive-pressure supplied-air respirator.		
	Hand protection:	Glove material: Vitron (R). Heat insulating gloves.		
	Eye protection:	Goggles.		
	Skin and body protection:	Wear suitable protective equipment. Protective footwear.		

## 9. Physical and Chemical Properties

Form:	Liquefied gas.
Appearance/colour:	Colourless.
Odour:	Slight, ether-like.
Boiling point:	-19°C.
Flash point:	Does not flash.
Auto-ignition temperature:	368°C.
Lower explosion limit:	No LEL and UEL was assigned at standard testing conditions, 20°C. Exhibits flame limits at temperatures in excess of 28°C.
Upper explosion limit:	No LEL and UEL was assigned at standard testing conditions, 20°C. Exhibits flame limits at temperatures in excess of 28°C.
Vapour pressure:	4.271 hPa at 20°C.
Vapour pressure:	11.152 hPa at 54.4°C.
Density:	1.17 g/cm <sup>3</sup> at 21.1°C.
Ph:	Neutral.
Solubility in water:	0,373 g/l.
Partition coefficient (n-octanol/water):	log Pow 1.6.
Relative vapour density:	4 (Air = 1.0).

### 10. Stability and Reactivity

<b>Conditions to avoid:</b>	Some risk may be expected of corrosive and toxic decomposition products. Avoid heat, flames and sparks.
<b>Materials to avoid:</b>	Reactions with alkali metals.
<b>Hazardous decomposition products:</b>	Pyrolysis products containing fluoride. Fluorocarbons. Hydrogen fluoride.
<b>Stability and reactivity:</b>	Stable under normal conditions. Hazardous decomposition products formed under fire conditions. To avoid thermal decomposition, do not over heat.

### 11. Toxicological Information

<b>Acute oral toxicity:</b>	Not applicable.
<b>Acute dermal toxicity:</b>	No data available.
<b>Acute inhalation toxicity:</b>	LC50/rat, value: >207000 ppm, >965 mg/l. Exposure time: 4 h.
<b>Skin irritation:</b>	Species: rabbit, result: no skin irritation. Method: OECD Test guideline 404.
<b>Eye irritation:</b>	No data available.
<b>Sensitisation:</b>	Species: human, classification: non-sensitizing.
<b>Further information:</b>	Not mutagenic in Ames Test. May cause headache and dizziness. No experimental indications on genotoxicity in vivo found. Detailed toxicological data and examinations, exceeding the data set in the MSDS are available for professional users on request.

### 12. Ecological Information

#### Persistence and degradability

<b>Biodegradability:</b>	Aerobic. Result: Not readily biodegradable.
--------------------------	---

#### Ecotoxicity effects:

Effects:		Species:	Value:	Exposure time:	Comments:
Toxicity to fish.	NOEC	Cyprinus Carpio (Carp)	>117 mg/l	96 h	
Toxicity to aquatic plants.	NOEC	Algae	>170 mg/l	96 h	Growth inhibition
Acute toxicity to aquatic invertebrates.	EC50	Daphnia magna (Water Flea)	>160 mg/l	96 h	

### 13. Disposal Considerations

<b>Product:</b>	Dispose according to legal requirements. Contact manufacturer.
<b>Packaging:</b>	Legal requirements are to be considered in regard of reuse or disposal of used packaging materials.
<b>Further information:</b>	Provisions relating to waste: EC Directive 2006/12/EC; 91/689/EEC Regulation No. 1013/2006.

## 14. Transport Information

ADR/RID:	Class:	2.
	Classification code:	2A.
	Un number:	3163.
	Hazard labels:	2.2.
	Proper shipping name:	Liquified Gas, N.O.S. (Trans-1,3,3,3-Tetrafluoroprop-1-ene).
	Hazard number:	20.
	Environmentally hazardous:	No.
IATA:	Class:	2.2.
	Un number:	3163.
	Hazard labels:	2.2.
	Proper shipping name:	Liquified Gas, N.O.S. (Trans-1,3,3,3-Tetrafluoroprop-1-ene).
IMDG:	Class	2.2
	Un number	3163
	Hazard labels	2.2
	Proper shipping name	Liquified Gas, N.O.S. (Trans-1,3,3,3-Tetrafluoroprop-1-ene)
	Ems number	F-C,S-V
	Marine pollutant	No

## 15. Regulatory information

Safety, health and environmental regulations/legislation specific for the substance or mixture.

## Other inventory information:

Country	Legislation	Information
US	Toxic Substances Control Act.	On TSCA inventory.
Australia	Industrial Chemical (Notification & Assessment) Act.	Not in compliance with inventory.
Canada	Canadian Environmental Protection Act (CEPA).	Not in compliance with inventory.
	Domestic Substances List (DSL).	
Japan	Kashin-Hou Law List.	On the inventory or in compliance with the inventory.
Korea	Existing Chemicals Inventory (KECI).	Not in compliance with inventory.
Philippines	The Toxic Substances and Hazardous and Nuclear Waste Control Act.	Not in compliance with inventory.
China	Inventory of Existing Chemical Substances.	On the inventory or in compliance with the inventory.
New Zealand	Inventory of Chemicals (NZIoC), as published by ERMA New Zealand.	Not in compliance with inventory.



### 16. Other Information

Abbreviations:	EC:	European Community.
	CAS:	Chemical Abstract Service.
	WEL:	Workplace Exposure Limit.
	MAK:	Maximale Arbeitsplatz-Konzentration.
	AGW:	Arbeitsplatzgrenzwert.
	STEL:	Short Term Exposure Limit.

### Other inventory information:

When using this document care should be taken as the decimal sign and its position complies with rules for the structure and drafting of international standards and is a comma on the line. As an example 2,000 is two (to three decimal places) and not two thousand, whilst 1.000 is one thousand and not one (to three decimal places).

This data sheet contains changes from the previous version, CLP03 dated January 2018. Sections 1 and 9 have been updated.

This datasheet was prepared in accordance with Regulation (EC) No. 1907/2006.

Information given is, to the best of the Company's knowledge and belief, accurate and reliable. However, no warranty, guarantee or representation is made to its accuracy, reliability of completeness. An environmental hazard cannot be excluded in the event of unprofessional handling or disposal.

# Low Temperature Oil 57491

## MATERIAL SAFETY DATA SHEET

### 1. Low Temp Oil 57491 Product Information

<b>Trade/Type:</b>	Clavus Oil 15.
<b>Container:</b>	Plastic Bottle.
<b>Uses:</b>	For lubrication of microtomes and remote control spindles.
<b>Description:</b>	Low Temperature Oil.

### 2. Low Temp Oil 57491 Product Information

<b>Information on ingredients:</b>	Mineral oil	
<b>Physical and chemical properties:</b>	Form:	Liquid
	Density:	@15°C, Kg/1 0.878
	Odour:	Mineral oil odour
	Colour:	Pale amber
	Flashpoint:	153°C (IP 34PM closed cup)
<b>Stability and reactivity:</b>	Stable:	Yes
	Conditions to avoid:	Extreme temperatures store between 0 – 50°C
	Materials to avoid:	Strong oxidising agents
	Hazardous Decomposition/Combustion Products: Dependant of conditions bringing about decomposition the following substance may be expected from normal combustion: carbon dioxide – polycyclic Aromatic Hydrocarbons, carbon monoxide – Unburnt hydrocarbons, water – unidentified organic and inorganic compounds, particulate matter – nitrogen oxides.	
<b>Ecological information:</b>	Soil:	Will biodegrade
	Water:	Will not evaporate or dissolve
	Air:	Nil
	DO NOT allow to enter drainage systems, rivers or waterways.	

# Low Temperature Oil 57491

## MATERIAL SAFETY DATA SHEET

### 2. Low Temp Oil 57491 Product Information (Cont.)

<b>Hazards identification:</b>	Skin:	Unlikely to irritate on brief or occasional exposure.
	Respiratory:	Low volatility make inhalation unlikely at ambient temperatures.
	Ingest:	Possible aspiration into the lungs with possible resultant chemically induced pneumonia.
	Eyes:	May cause transient irritation.
<b>First aid procedures:</b>	Skin:	Wash thoroughly, with soap and water..
	Respiratory:	Remove from exposure.
	Ingest:	DO NOT induce vomiting. Wash out mouth with water. SEEK MEDICAL ATTENTION URGENTLY.
	Eyes:	Flush copiously for at least 15 minutes. If irritation persists SEEK MEDICAL ADVICE.
<b>Fire fighting measures:</b>	Extinguish fires with foam, dry powder, CO2 or water fog - do not use water jets.	
<b>Toxicological information:</b>	This product is NOT classified as dangerous for supply or conveyance.	
<b>Accidental release measures:</b>	Let spillages evaporate and ventilate area well.	
<b>Disposal considerations:</b>	Dispose waste in accordance with local authority requirements.	
<b>Handling storage:</b>	No special requirements. Store away from direct heat and avoid extremes of temperature. DO NOT leave container unsealed.	
<b>Transport information:</b>	Not classified as dangerous to transport.	
<b>Exposure controls:</b>	5mg/m <sup>3</sup> (8hour TWA) and 10mg/m <sup>3</sup> (15 minute reference period) (Ref: EH40/1999).	
<b>Regulatory information:</b>	This product is a preparation and is NOT classified according to EEC Guideline.	

# References & Drawings

# Figure A. Quick Freezer Bar

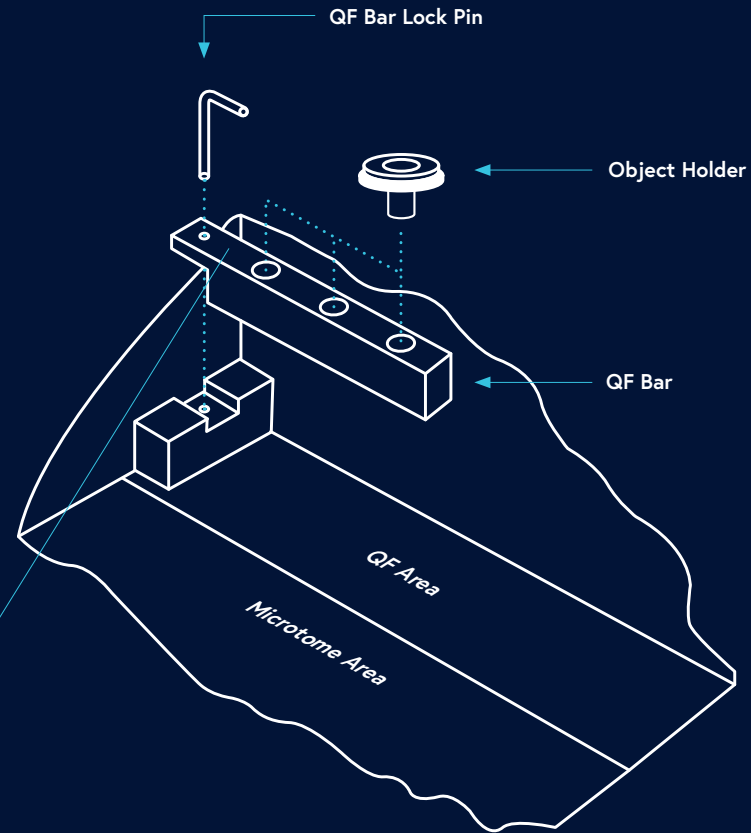
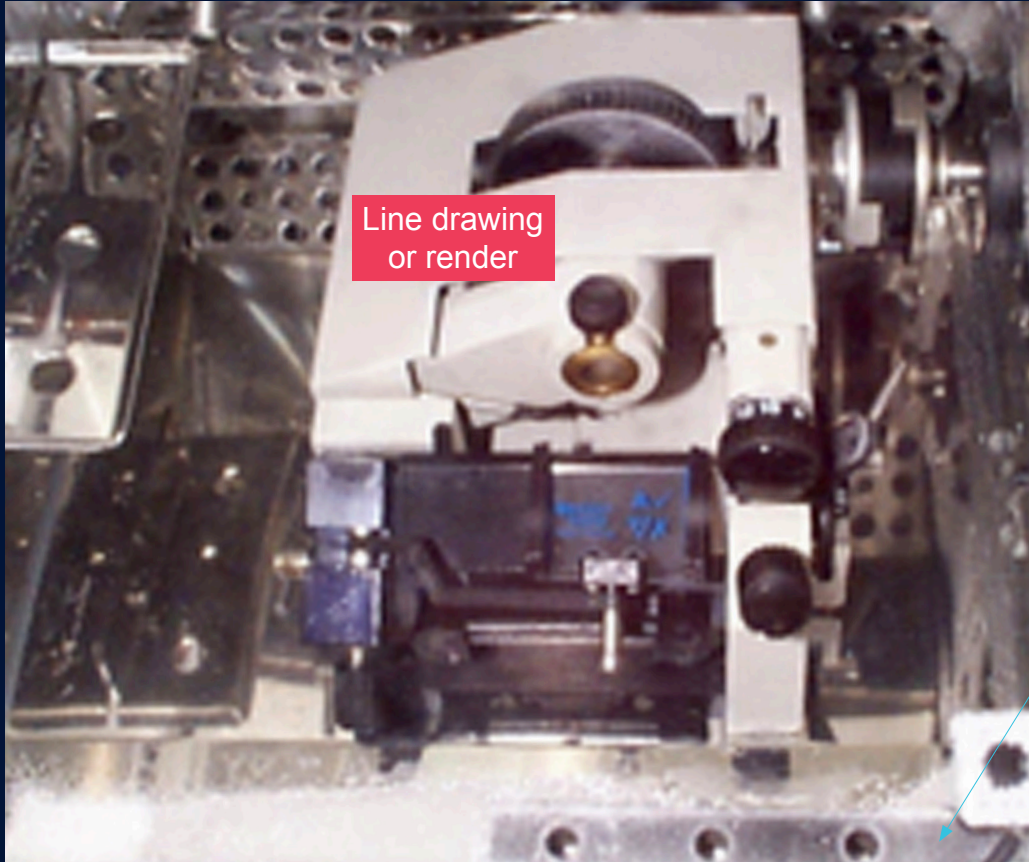

# Figure 1. Blade Holder

1. Anti-roll Plate Height Adjuster
2. Magnets
3. Anti-roll Plate
4. Blade Guard shown open

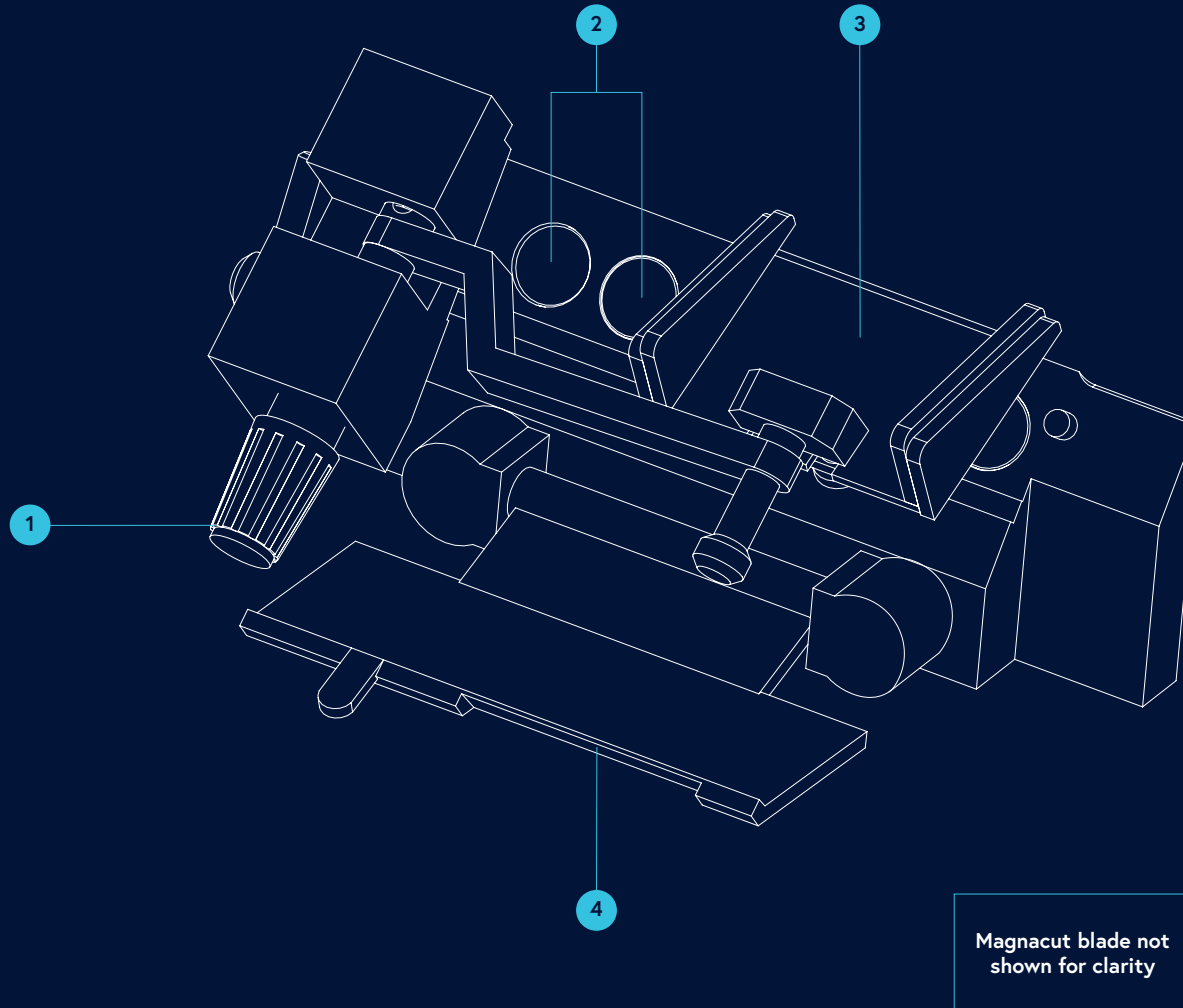

## Figure 2. Blade Angle

- 24. Knife Angle Adjuster
- 25. Lock Screw
- 39. Blade Holder Clamp Knob

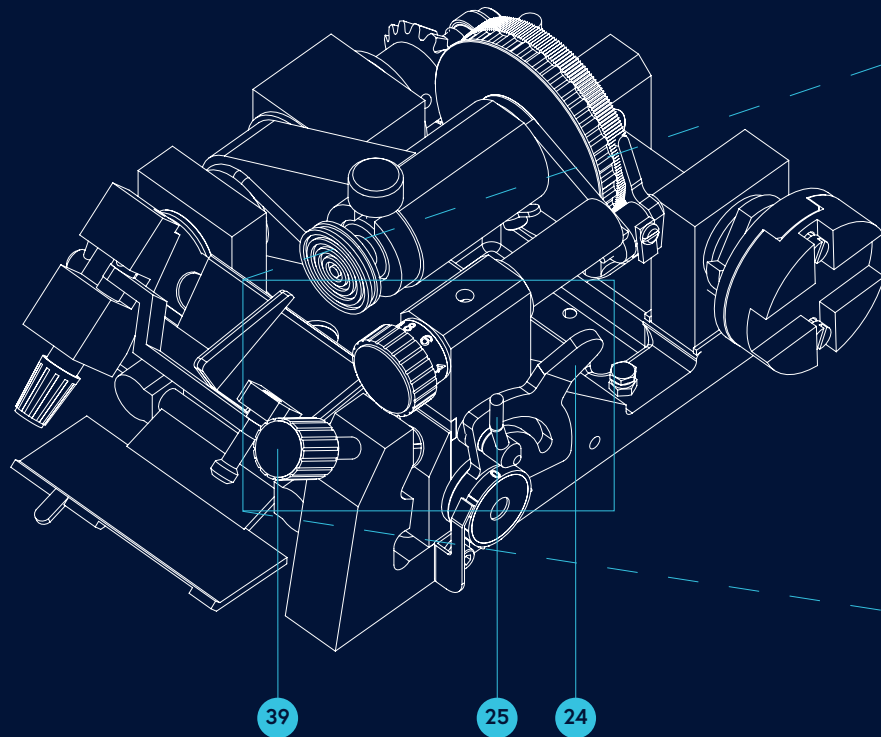

## Figure 3. Blade Angle Adjustment

- 24. Knife Angle Adjuster
- 25. Lock Screw
- 39. Blade Holder Clamp Knob

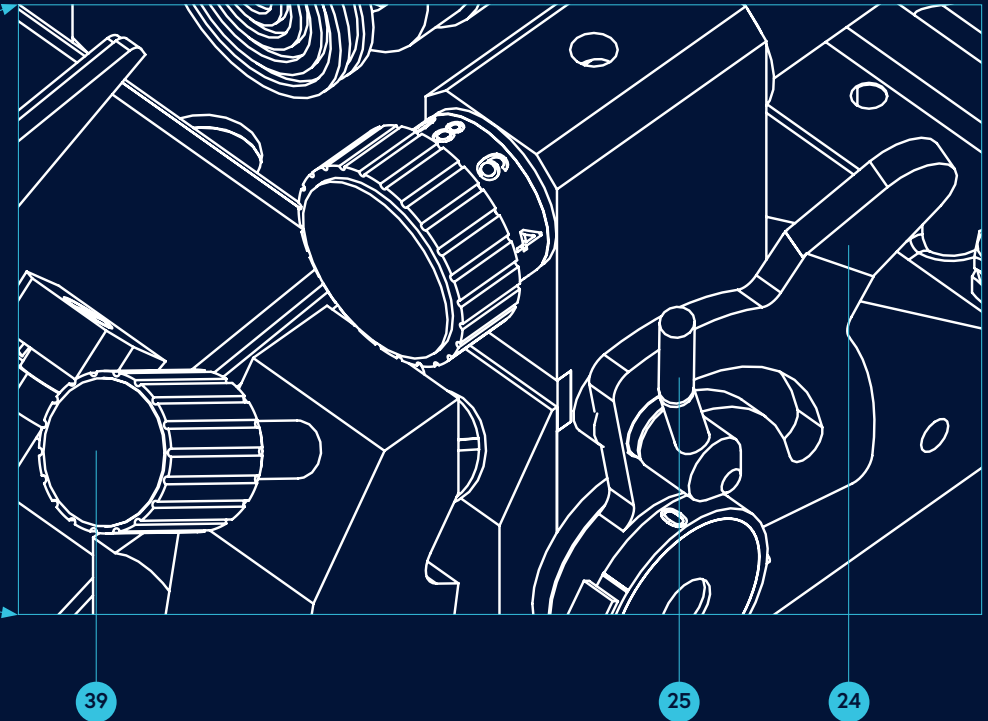

## Figure 4. Coarse Advance Control

14. Ratchet Wheel

17. Pawl

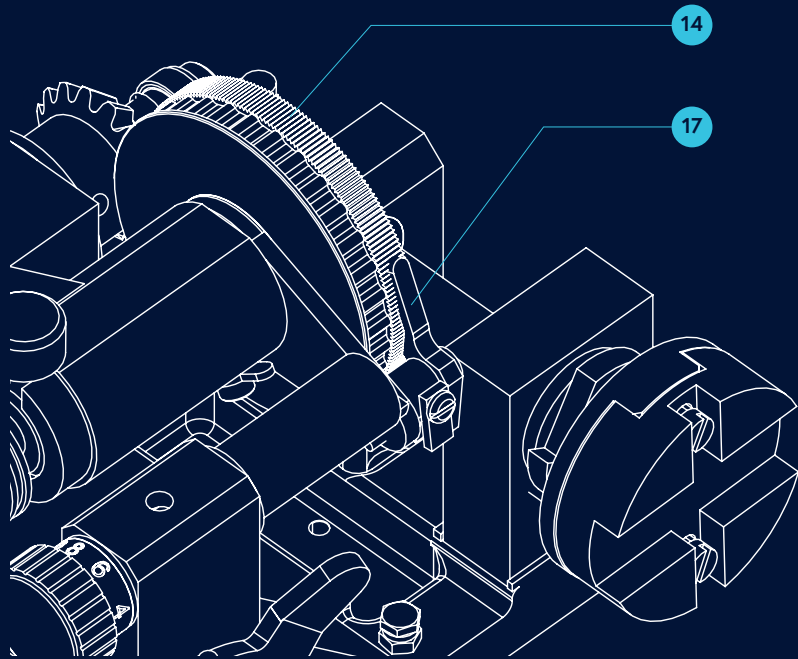

## Figure 5. Section Thickness Control

28. Micron Indexing Dial

39. Blade Holder Clamp Knob

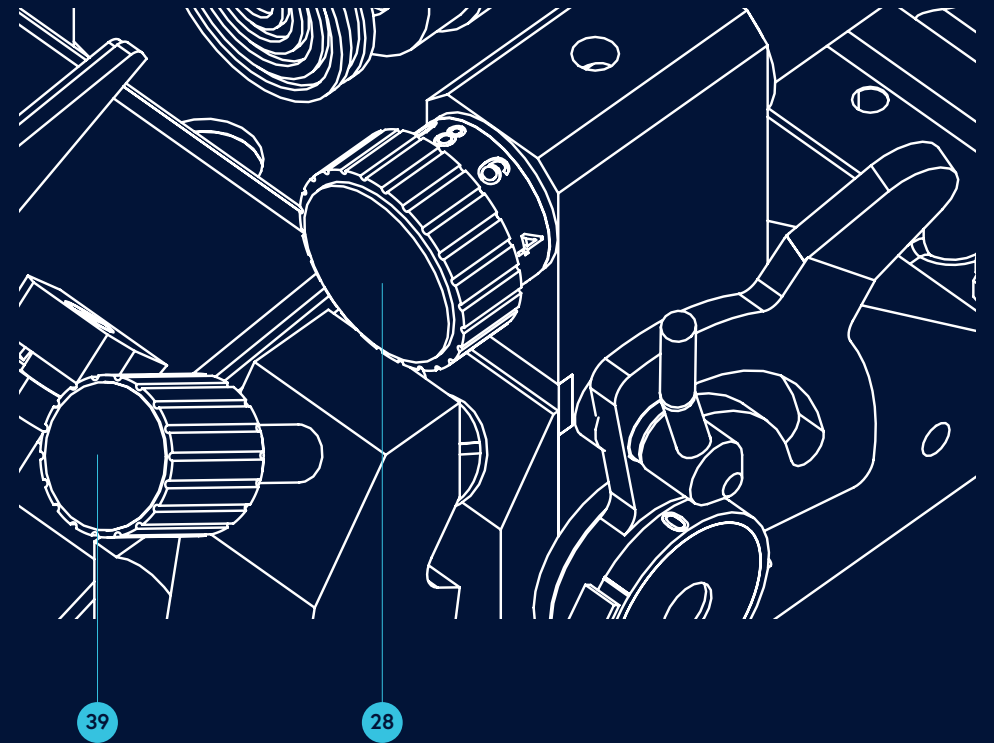



# Figure 10. Trimming

17. Pawl

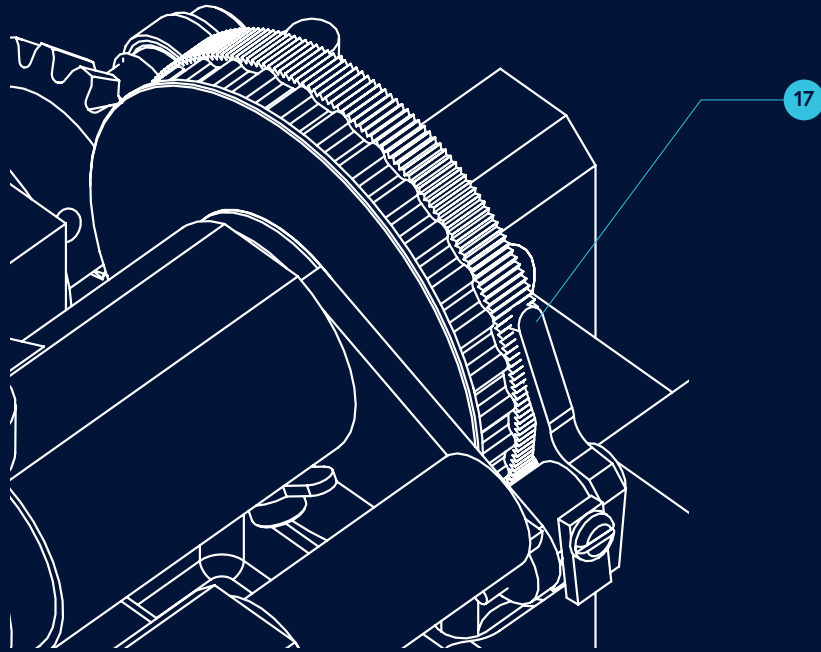

# Figure 11. Trimming

12. Carrier Head

14. Ratchet Wheel

17. Pawl

20. Clamp Screw

200. Rotary Main Shaft

203. Coupling Joint

208. Main Shaft Coupler

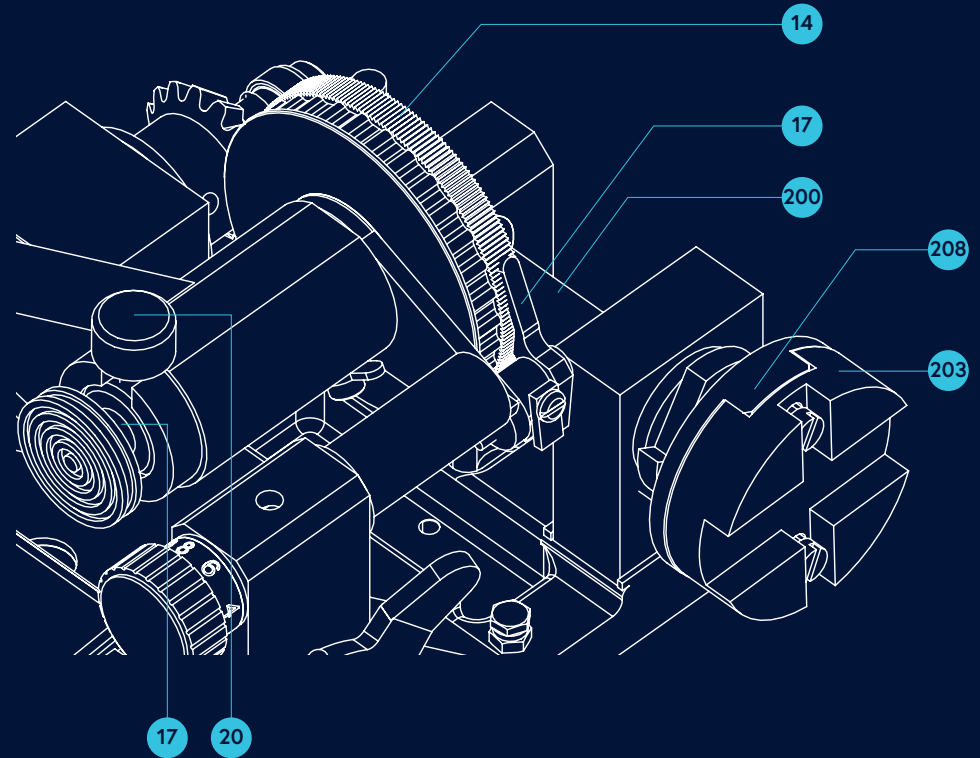

# Figure 15. Pawl Assembly

- 16. Spacer
- 17. Pawl
- 19. Pawl Spring
- 73. Pawl Spring Backing Plate
- 97. Screw
- 107. Roll Pin



# Figure 16. Pawl Adjustment

- 13. Pawl Arm
- 14. Ratchet Wheel
- 17. Pawl
- 18. Pivot Lock Screw

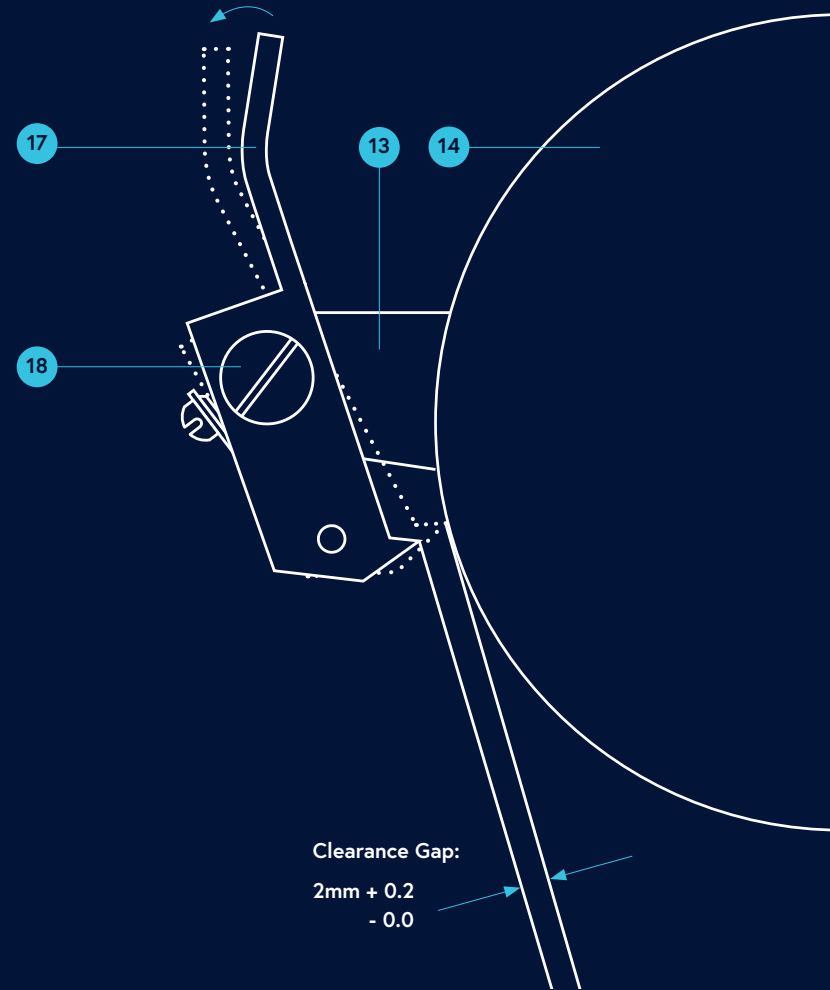

# Rotary Handwheel Diagram

(Refer to Fig.11)

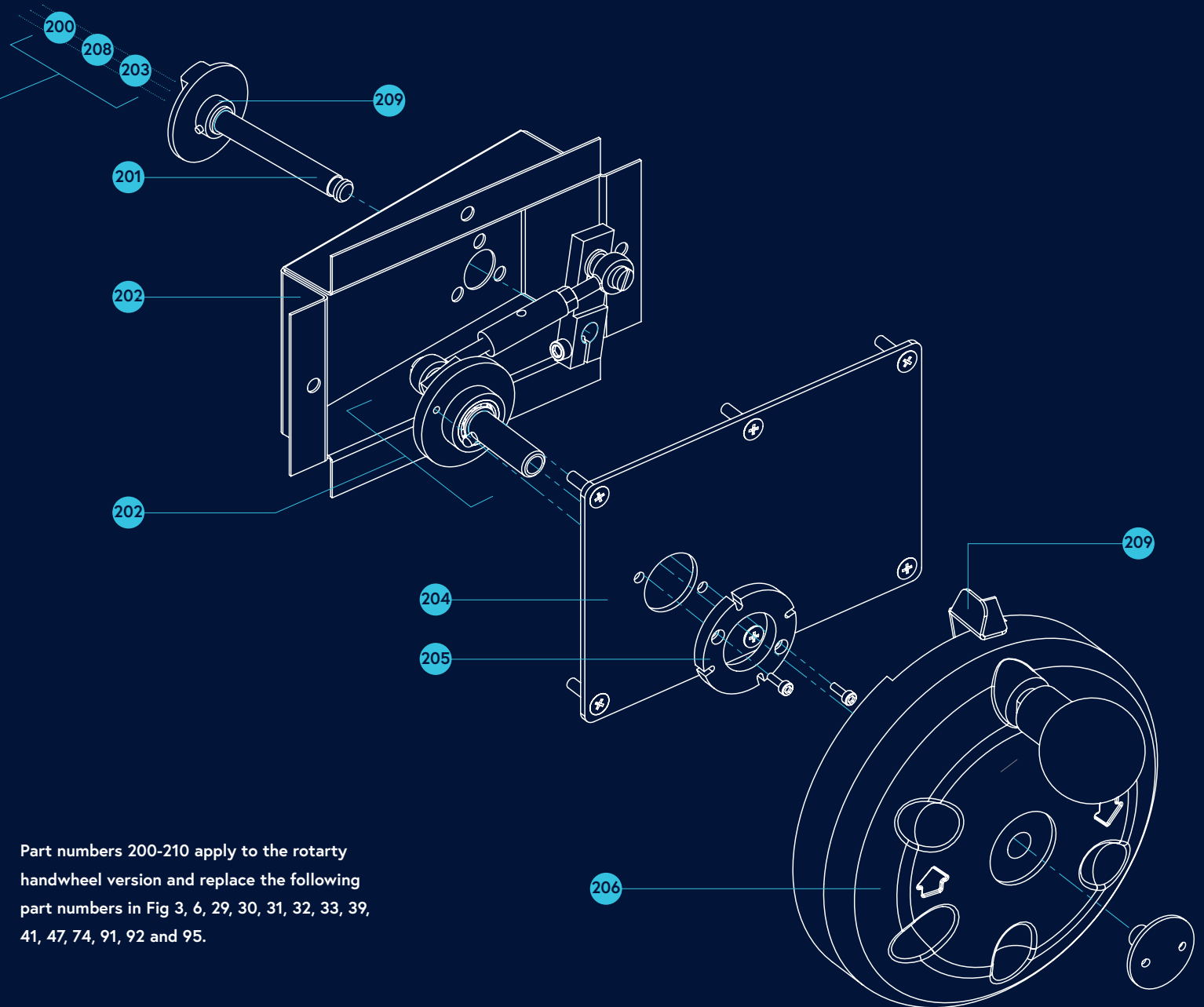

- 200 Rotary Main Shaft (Refer to Fig.11)
- 201 Drive Shaft
- 202 Drive Box
- 203 Coupling Joint (Refer to Fig.11)
- 204 Drive Box Cover Plate
- 205 Cutting Handle Stop Ring
- 206 Rotary Handwheel
- 207 Handwheel Locking Lever
- 208 Main Shaft Coupler (Refer to Fig.11)
- 209 Drive Shaft Coupler
- 210 Drive Mechanism

Part numbers 200-210 apply to the rotary handwheel version and replace the following part numbers in Fig 3, 6, 29, 30, 31, 32, 33, 39, 41, 47, 74, 91, 92 and 95.

# DWG: 136026-01

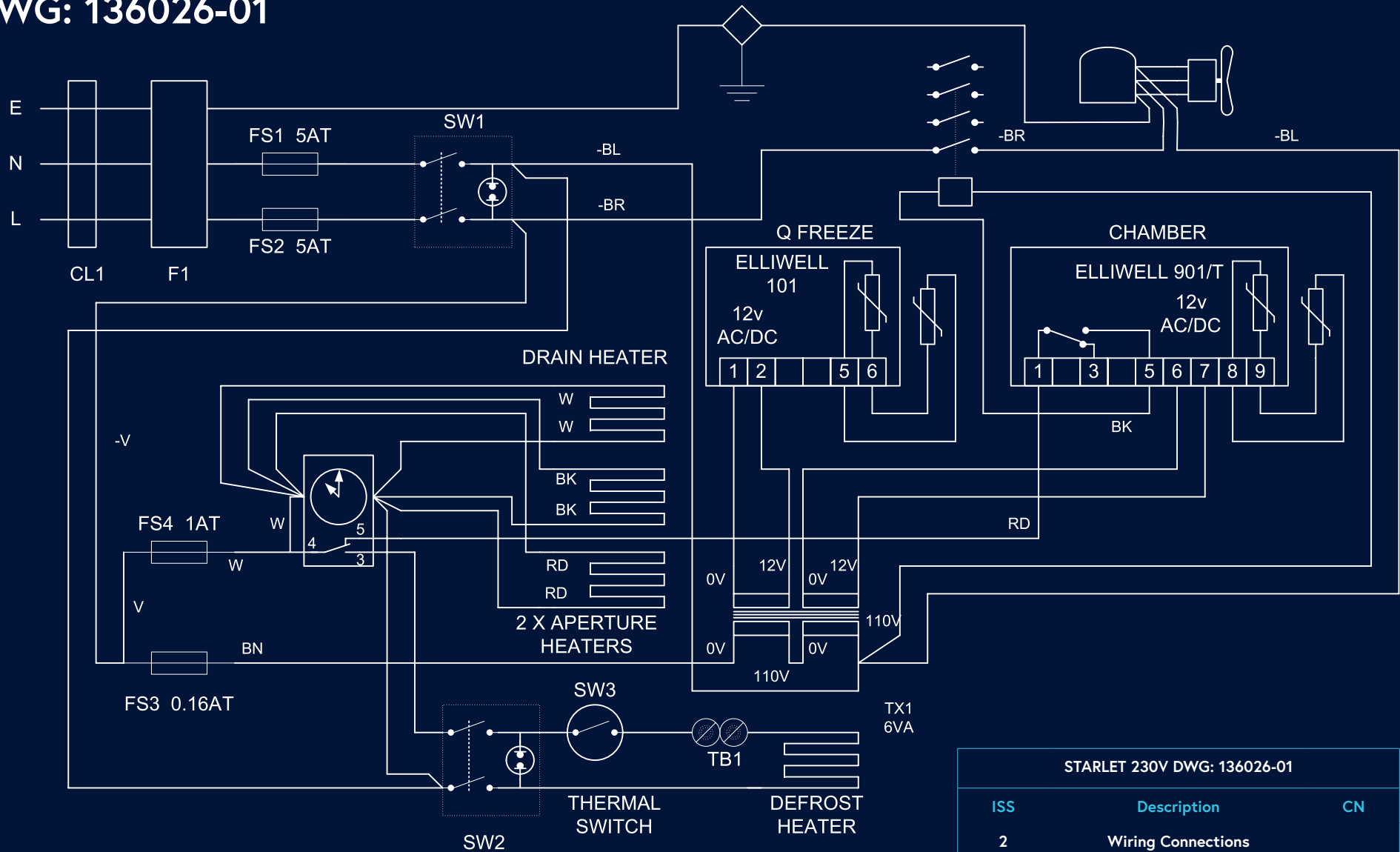

WIRE IDENTIFICATION +1.5mm -1.0mm ELSE 0.5mm

BK. Black	BL. Blue	GY. Grey	P. Pink	V. Violet	Y. Yellow
BR. Brown	GN. Green	OR. Orange	RD. Red	W. White	

## STARLET 230V DWG: 136026-01

ISS	Description	CN
2	Wiring Connections	
3	DEF HTR Fuse 1AT	
4	Filter Added	CN1895
5	Convert to Visio	
6	Interim Wire Colour Change	CN2478



# WolfLabs

**Pricing on any accessories shown can be found by keying the part number into the search box on our website.**

The specifications listed in this brochure are subject to change by the manufacturer and therefore cannot be guaranteed to be correct. If there are aspects of the specification that must be guaranteed, please provide these to our sales team so that details can be confirmed.

**[www.wolflabs.co.uk](http://www.wolflabs.co.uk)**

**Tel : 01759 301142**

**Fax : 01759 301143**

**[sales@wolflabs.co.uk](mailto:sales@wolflabs.co.uk)**

Please contact us if this literature doesn't answer all your questions.